

Specification M.O.A./CV.7147 Issue No. 1 Dated 15.6.61 To be read in conjunction with K.1007	<u>SECURITY</u>	
	<u>Specification</u> UNCLASSIFIED	<u>Valve</u> UNCLASSIFIED

<p>TYPE OF VALVE: Silicon, Broadband, Low Level, Detector Crystal Q-Band</p> <p>FREQUENCY RANGE: 26.0 Gc/s to 40.0 Gc/s</p> <p>CONSTRUCTION: Co-axial Shielded</p> <p>PROTOTYPE: VX.4150</p> <p>CLIMATIC PERFORMANCE: Although these valves are intended to be fully par-climatic, some samples may not stand exposure to high humidity conditions for long periods without deterioration in performance. The valves should be used in sealed units and should not be removed from their protective packing until required for use.</p> <p>POLARITY: The pin is equivalent to the cathode of a thermionic diode.</p>	<u>MARKING</u>
	See K.1007/4 CV. No. and if possible the factory and date code.
	<u>DIMENSIONS</u>
	See drawing on Page 4
	<u>PACKAGING</u>
	See K1007/14

NOTES

- The Joint Services Catalogue Number is 5960-99-037-2399

TESTS

To be performed in addition to those applicable in K.1007

K.1007 Ref.	Test	Test Conditions	AQL %	Insp. Level	Sym-bol	LIMITS		Units
						Min.	Max.	
	<u>Group A</u>							
	Voltage Standing Wave Ratio	f.(1) 26.1 Gc/s $\pm 0.1\%$ f.(2) 31.6 Gc/s $\pm 0.1\%$ f.(3) 40.0 Gc/s $\pm 0.1\%$ Note 1	-	100%	-	-	-	-
	Video Resistance	Input 1 mV max. Note 1	-	100%	Rv	3000	12000	Ohms
	Figure of Merit	Frequency = 31.6 Gc/s $\pm 0.1\%$ Notes 1, 2.	-	100%	M	15	-	-

Groups B and C omitted

	<u>Group D</u>							
	Burn out	10 mW R.F. peak power shall be applied to the valve f = 35 Gc/s $\pm 1\%$ P.R.F. = 1000 ± 100 p.p.s. tp = 0.25 ± 0.05 μ Sec. Duration 1 hour Notes 1, 3, 4.	-	1B	-	-	-	-
	<u>Post Burnout Test</u>							
	Change in Figure of Merit (individual samples).	As in Group A	6.5	-	M	-40	+60	%
	<u>Group E</u>							
	Tensional	The valve shall be subjected to an axial tension of 2 lb. to the centre pin for 10 secs. Note 4.	-	1B	-	-	-	-
10.2	Temperature Cycling	Six cycles -40°C to +70°C Note 4	-	T.A.	-	-	-	-
10.3	Climatic	Duration = 7 days Note 5.						
	Vibrational Stability	The valves shall be vibrated at a nominal frequency of 50 c.p.s. in two mutually perpendicular planes, one of which, shall be along the major axis. Minimum duration 10 mins. in each plane. Min. peak acceleration 12g. Note 4.	-	1B	-	-	-	-

K.1007 Ref.	Test	Test Conditions	AQL %	Insp. Level	Spm- bol	LIMITS		Units
						Min.	Max.	
8	<u>Group E (cont'd.)</u>							
	Post Tensional Stability, Tempera- ture. Cycling, Climatic, Fatigue	Combined AQL (for each group of tests).	6.5	-	-	-	-	-
	Inoperatives Video Resistance Figure of Merit	As in Group A As in Group A	- - -	- - -	- Rv M	- 2700 13.5	- 13200 -	- Ohm -

NOTES

- The valves shall be tested in a holder, which at the frequency of test, gives a V.S.W.R. of not less than 0.95 when the valves are replaced by a matched coaxial termination.
- Figure of Merit is to be taken as the product of current sensitivity, expressed in microamps per microwatt and the square root of video resistance in ohms. The current sensitivity is defined as the d.c. open-circuit voltage (mV/ μ W) developed across the valve, at an input level between 1 and 5 μ W C.W., divided by the video resistance (ohms). The open circuit voltage may be obtained by a backing off method, using a variable battery supply of low impedance which is adjusted to give zero current through the valve.
- The input power shall be derived from a source matched better than 0.5 V.S.W.R.
- Samples subjected to these tests shall not be accepted for delivery unless they also meet the limits specified in Group "A".
- Samples subjected to this test shall not be accepted for delivery.

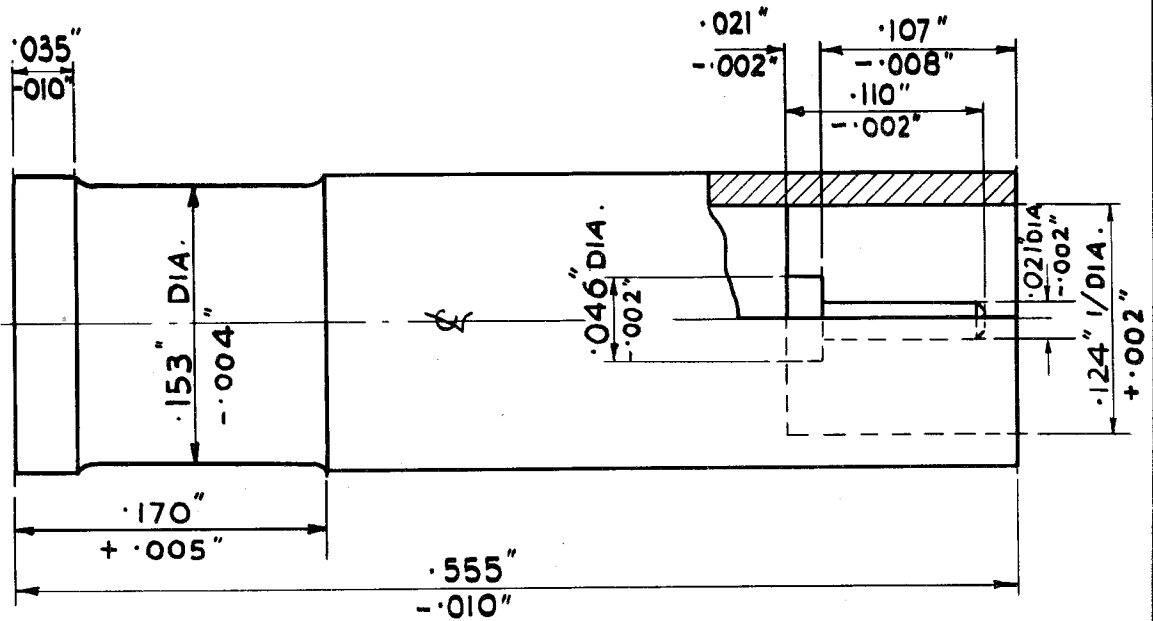

SCALE = 10x FULL SIZE.

NOTE :- THIS CRYSTAL VALVE
WILL FIT SAME HOLDER AS
IN 53.

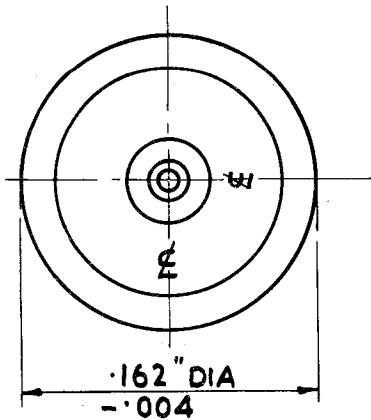

VIEW ARROW 'R'



ACTUAL SIZE

